

Life Fitness Model 8500, 9100, and 9500HR Cross-Trainers

How To... Replace The Frame Cover

Tools required: Phillips screwdriver, Standard screwdriver, Allen wrench set, 3/8" Socket set, and Wrenches

1. Remove the REAR COVERS. See How To... Remove Rear Covers.
2. Remove the FRONT COVER.
3. Remove the FRAME COVER which is adhered to the frame with double-back tape.
4. Install four(4) pieces of tape to the underside of the cover, then install the FRAME COVER.

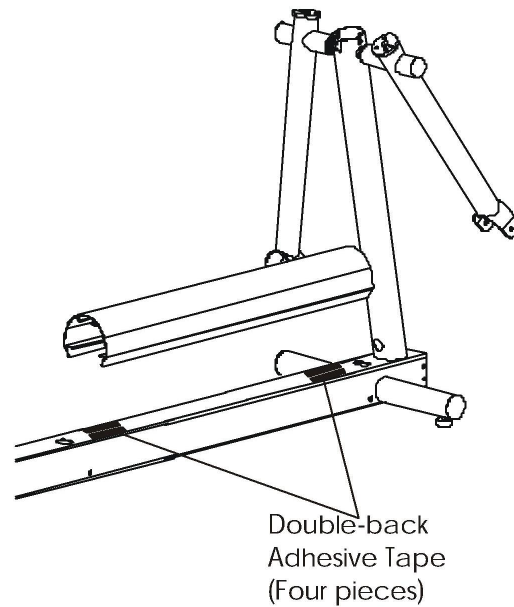
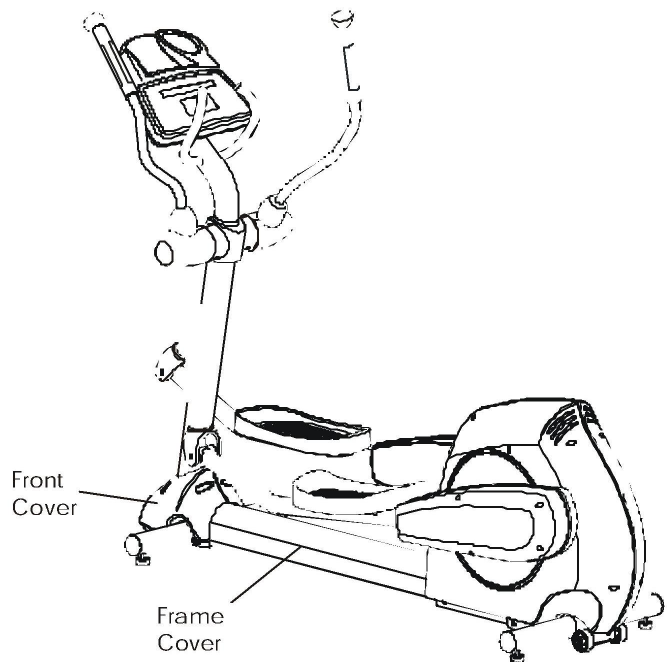

Section III